

# Installation Instructions

For 1.2m Ultra-High Performance Antenna

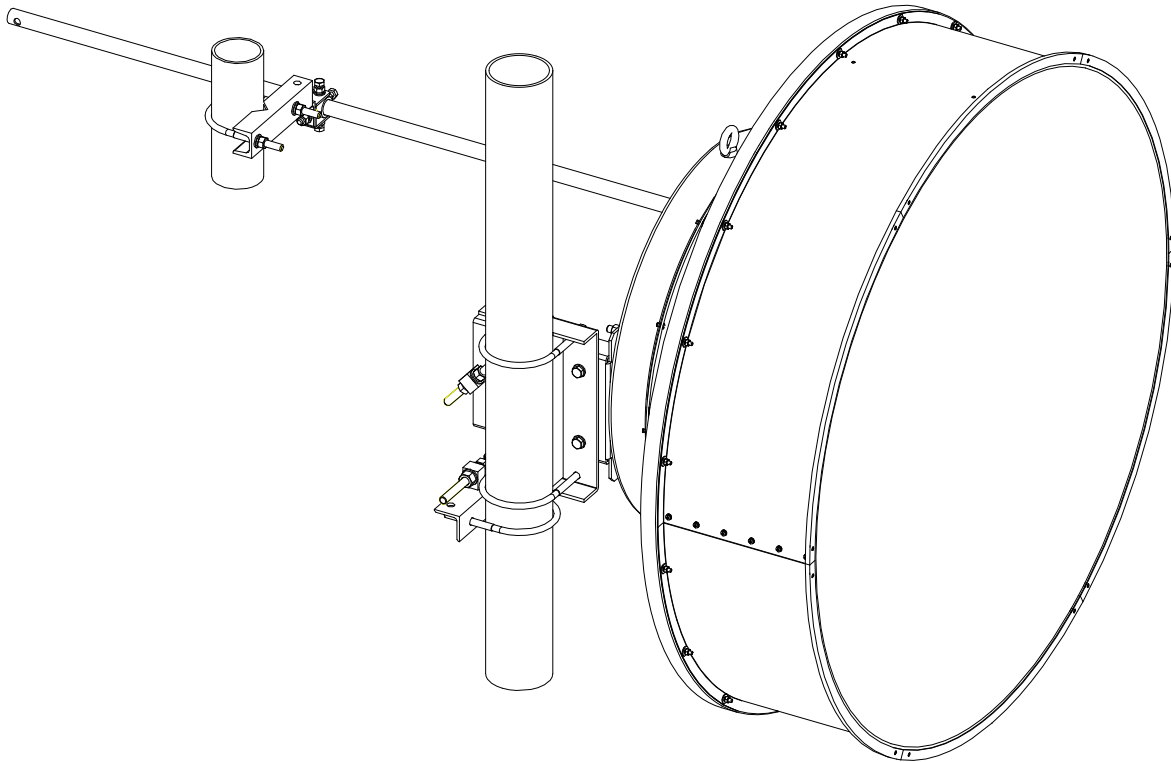

**Before Installation, please read the instruction carefully.**

- ◆ This instruction book is for the installation of the 1.2m (4 ft) diameter ultra-high performance microwave antenna.
- ◆ Installation, maintenance and removal of antenna should be done by qualified personnel.
- ◆ To guarantee performance, the antenna should be inspected once a year by qualified personnel.

# CONTENTS

<b>1. Installation Preparation</b> .....	<b>1</b>
1.1 Mounting Pole .....	1
1.2 Tools Required for Installation .....	1
1.3 Torque Parameters of Standard Parts .....	1
<b>2. Open the Package and Identify Parts</b> .....	<b>1</b>
<b>3. Mount Feeder</b> .....	<b>2</b>
<b>4. Mount Reflector Assembly</b> .....	<b>3</b>
<b>5. Mount Transition Section</b> .....	<b>3</b>
<b>6. Mount Hanging Bracket</b> .....	<b>4</b>
<b>7. Mount Anti-skid Bracket</b> .....	<b>4</b>
<b>8. Mounting to the Pole</b> .....	<b>5</b>
<b>9. Mount Sway Bar</b> .....	<b>5</b>
<b>10. Antenna Installation</b> .....	<b>6</b>
<b>11. Antenna Adjustment</b> .....	<b>6</b>
11.1 Elevation Adjustment.....	6
11.2 Azimuth Adjustment.....	7
11.3 Polarization Adjustment .....	7
<b>12. Antenna Assembly Finishing</b> .....	<b>8</b>

# 1. Installation Preparation

## 1.1 Mounting Pole

The antenna must be fixed to a Mounting Pole with a diameter of approximately 4.5 inches (114 mm).

## 1.2 Tools Required for Installation

20×200 Adjustable Spanner (*Used for bolt M12-M16*)

10mm Open-end Spanners (*Used for bolt M6*)

17-19 Open-end Spanners (*Used for bolt M12*)

3mm L-Spanner (*Used for Bolt M4*)

Cross Screwdriver (*Used for Bolt M6*)

Torque Spanner (*Recommended*)

Pliers

## 1.3 Torque Parameters of Standard Parts

Please use the following torque specifications when assembling the antenna.

Table of Torque Parameters

NO.	Types of Standard Parts	Torque (N·m)
1	M4	1.3
2	M5	3
3	M6	5
4	M10	28
5	M12	49
6	M14	78
7	M16	122

# 2. Open the Package and Identify Parts

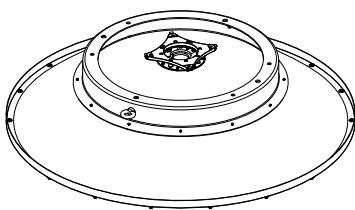

Reflector Assembly (1 set)

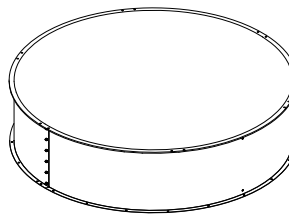

Shroud Assembly (1 set)

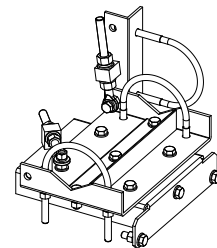

Hanging Bracket (1 set)

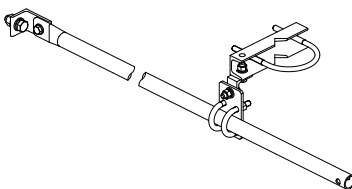

Sway Bar (1 set)

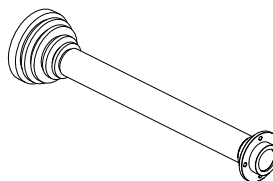

Feeder (1 set)

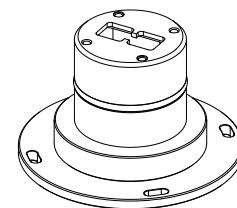

Transition Section (1 set)

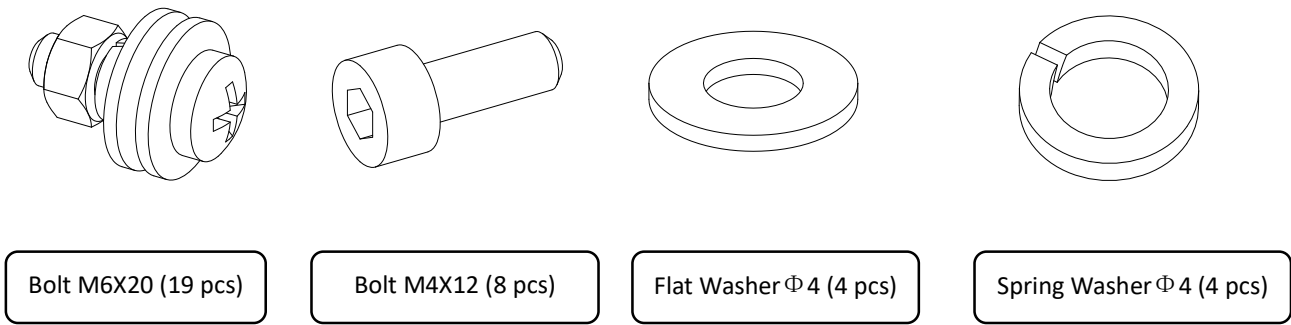

**Fig 2.1 Parts Guide**

**3. Mount Feeder**

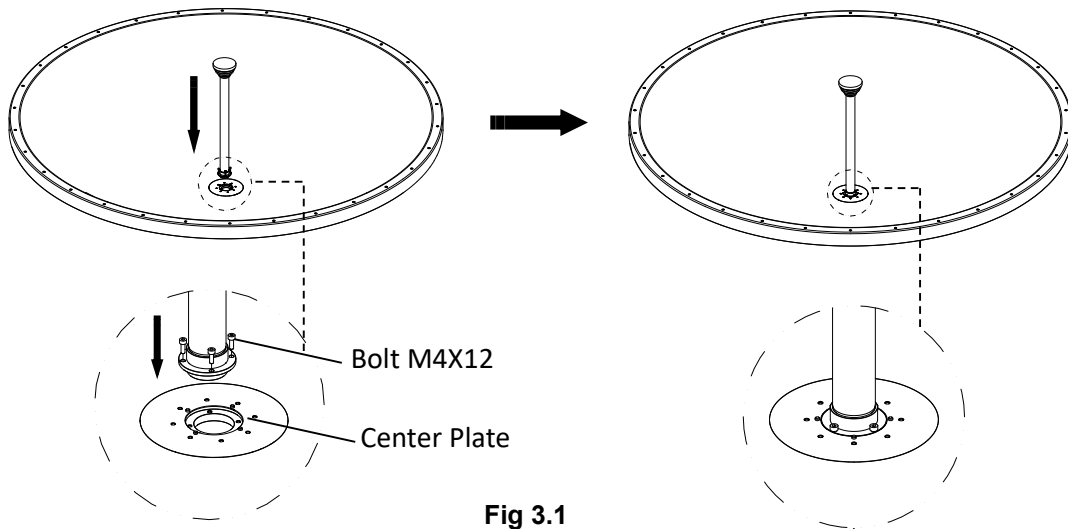

3.1 Put Feeder into the Center Plate, and then tighten bolts (shown in Fig 3.1). Ensure that the feed is seated properly before tightening the bolts.

## 4. Mount Reflector Assembly

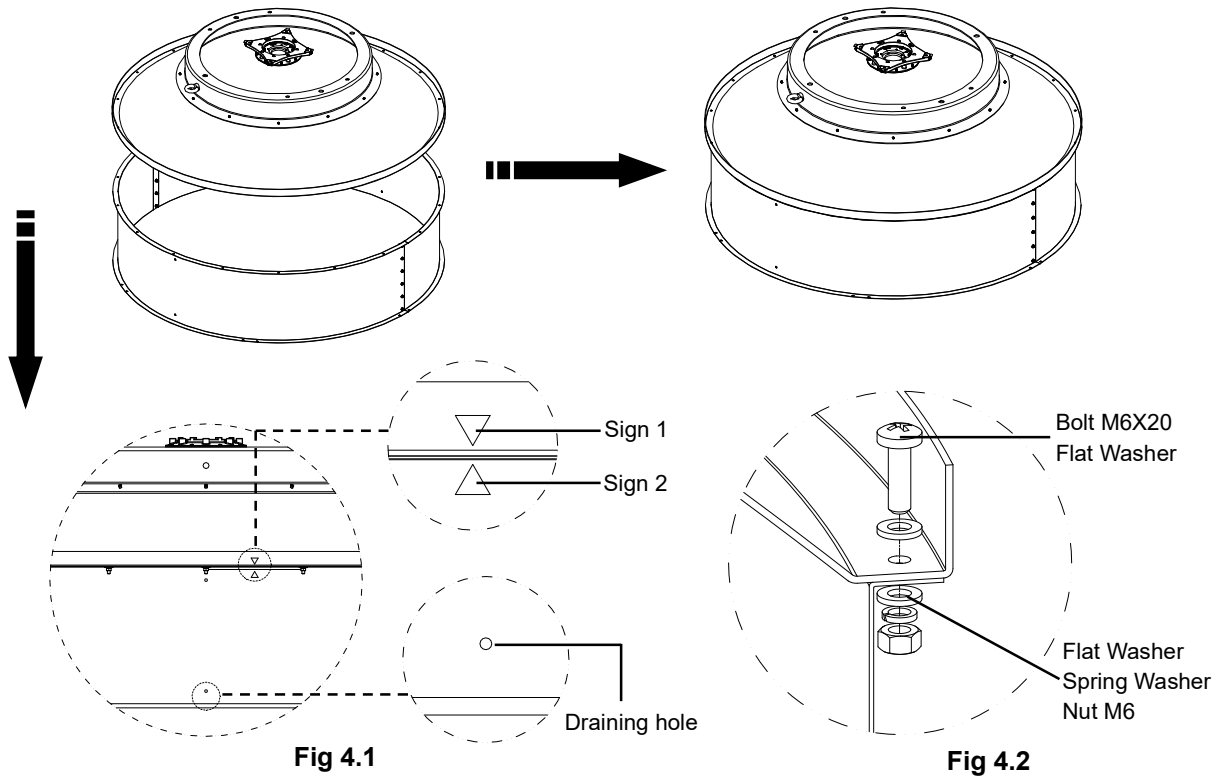

- 4.1 Turn the Reflector Assembly over, and then fit it onto the Shroud Assembly with Sign 1 and Sign 2 aligned (shown in Fig 4.1).
- 4.2 Use M6X20 Bolt, Flat Washer, Spring Washer, and Nut (18pcs) to connect Reflector Assembly with Shroud Assembly (shown in Fig 4.2).
- 4.3 Tighten all the standard parts.

## 5. Mount Transition Section

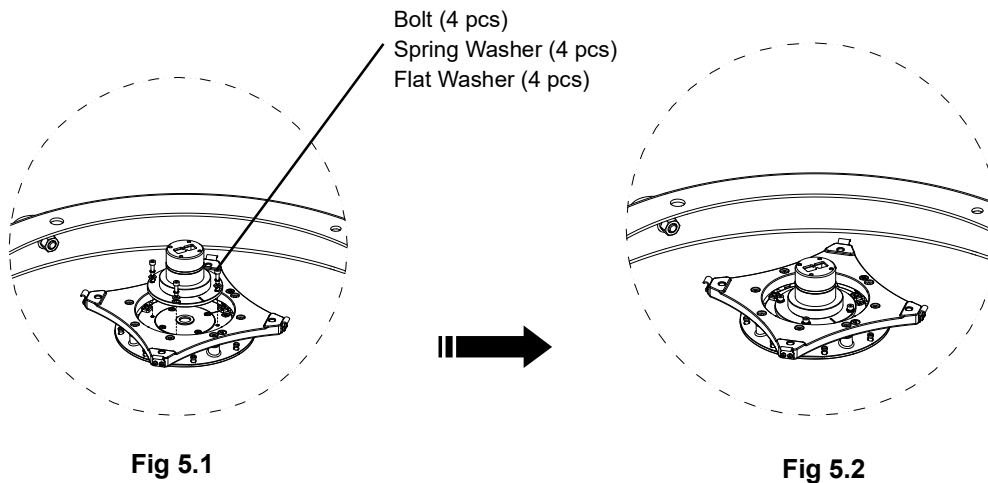

- 5.1 Put Transition Section into the Center Plate, and then use bolt (4 pcs) to connect these two parts (shown in Fig 5.1). Ensure the Oring is seated properly.
- 5.2 Tighten all the standard parts (shown in Fig 5.2).

## 6. Mount Hanging Bracket

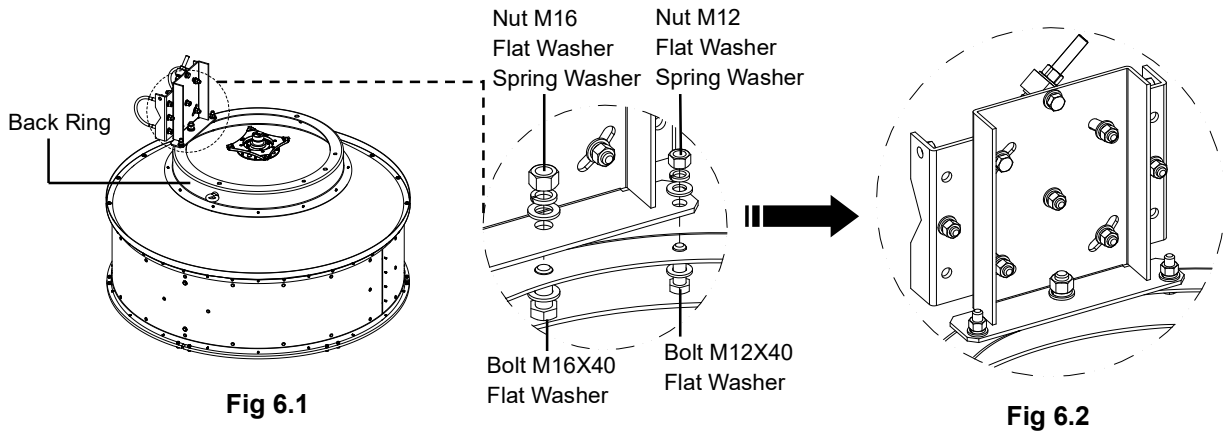

- 6.1 Put Hanging Bracket into the Back Ring, and then use M12X40 bolt (2 pcs) and M16X40 bolt (1 pcs) to connect these two parts (shown in Fig 6.1).  
 6.2 Tighten all the standard parts (shown in Fig 6.2).

## 7. Mount Anti-skid Bracket

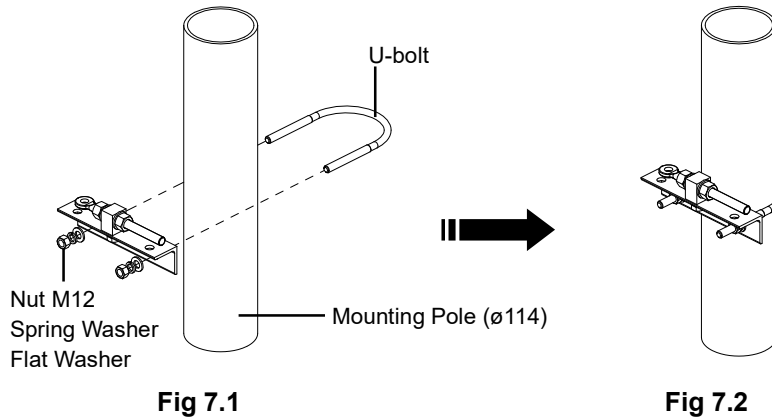

- 7.1 Fix Anti-skid Bracket to the Mounting Pole (shown in Fig 7.1).  
 7.2 Tighten all the standard parts (shown in Fig 7.2).

## 8. Mounting to the Pole

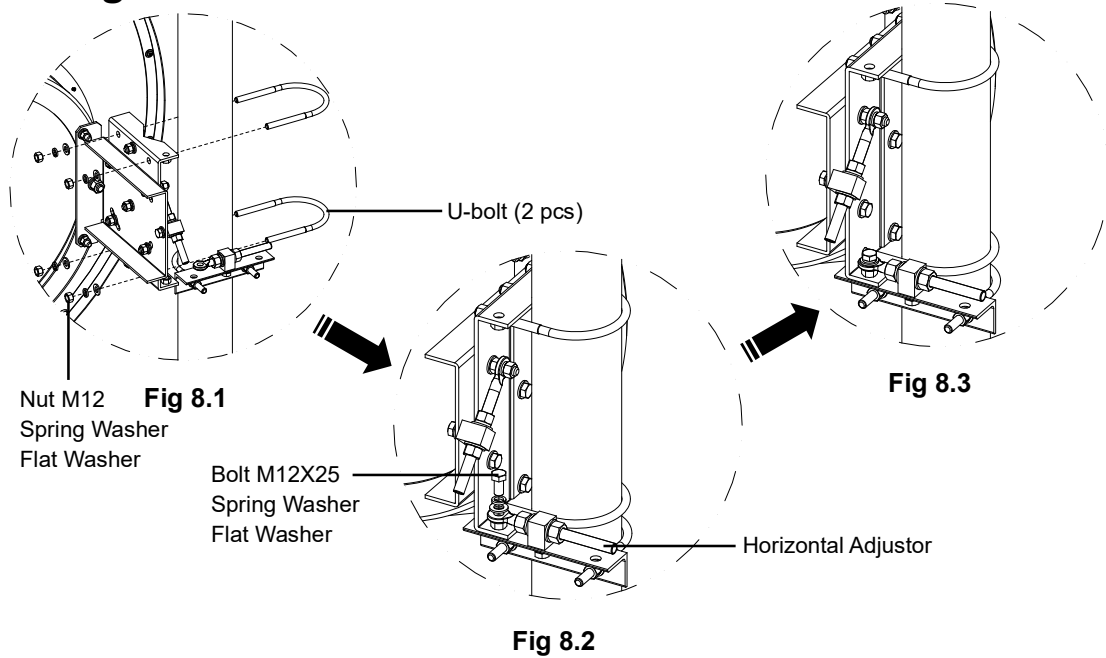

8.1 Mount antenna to the pole by 2 U-bolts (shown in Fig 8.1).

8.2 Use M12X25 bolt to connect Horizontal Adjustor with Hanging Bracket (shown in Fig 8.2).

8.3 Tighten all the standard parts (shown in Fig 8.3).

## 9. Mount Sway Bar

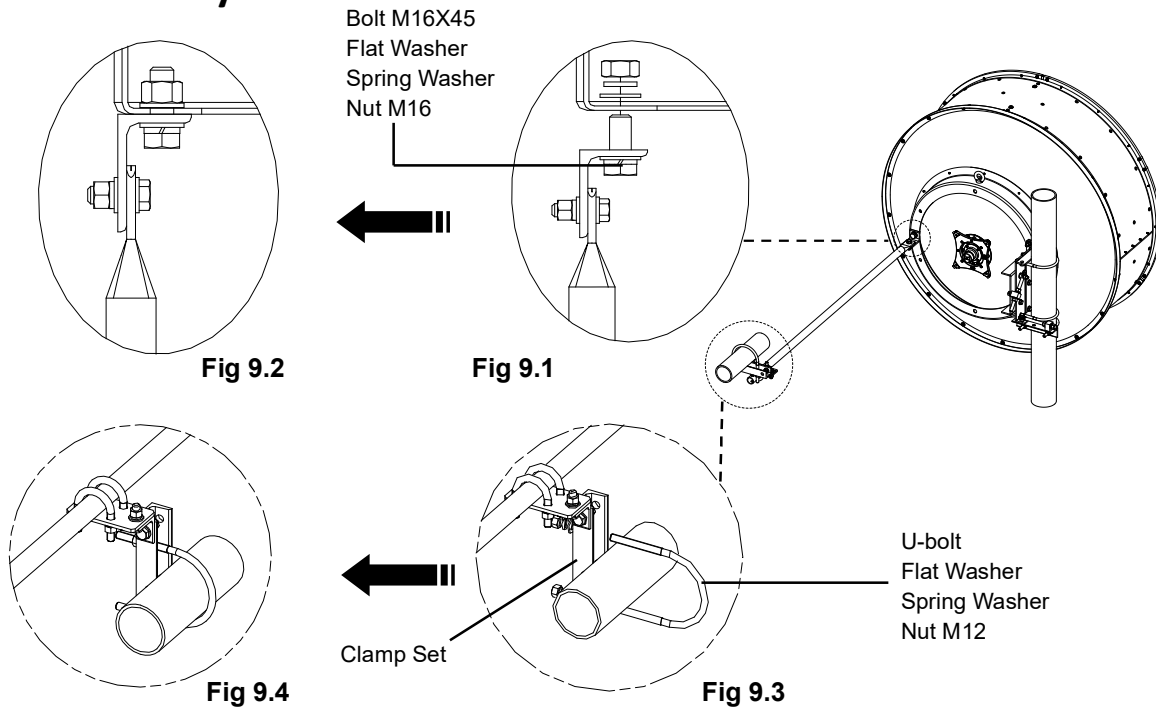

9.1 Use M16X45 bolt to connect Sway Bar with antenna's Back Ring (shown in Fig 9.1).

9.2 Fix Clamp Set to the tower.

9.3 Tighten all the standard parts (shown in Fig 9.2 & Fig 9.4).

## 10. Antenna Installation

The antenna can be installed on either the left or right hand side of the pole (shown in Fig 10.1).

### Left-hand installation view

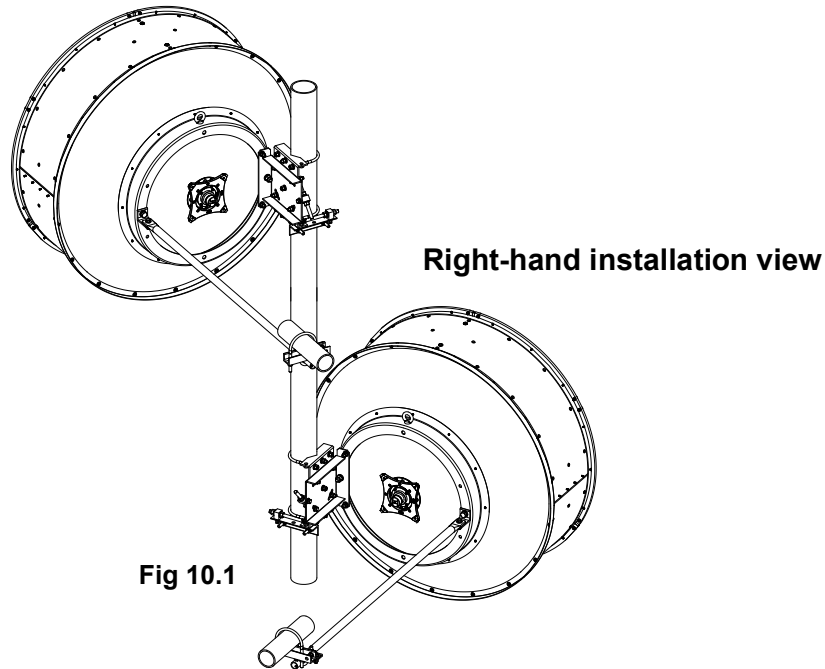

## 11. Antenna Adjustment

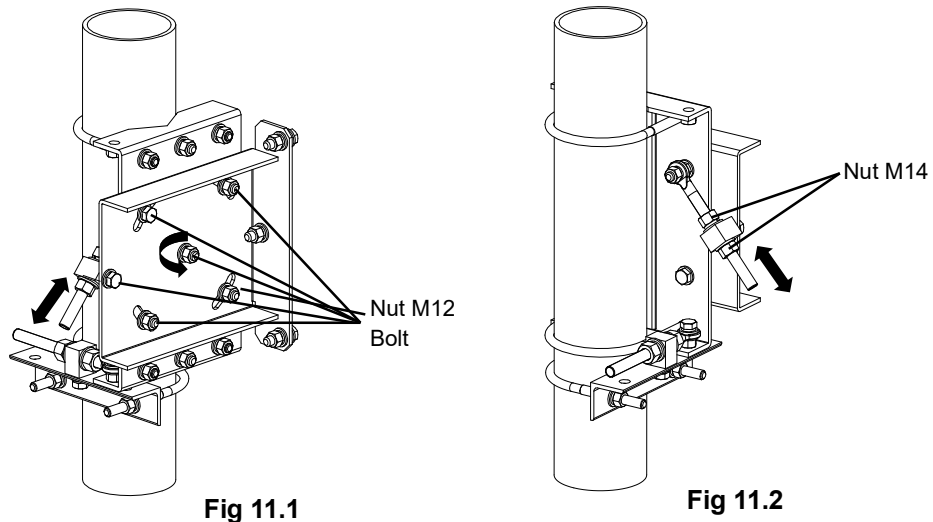

### 11.1 Elevation Adjustment

- ① Loosen M12 Nut and bolt (shown in Fig 11.1), and then rotate M14 Nut clockwise or counterclockwise to make elevation adjustment (shown in Fig 11.2).
- ② Antenna can be adjusted from  $-10^{\circ}$  to  $+10^{\circ}$ .
- ③ Tighten all the standard parts.



## 11.2 Azimuth Adjustment

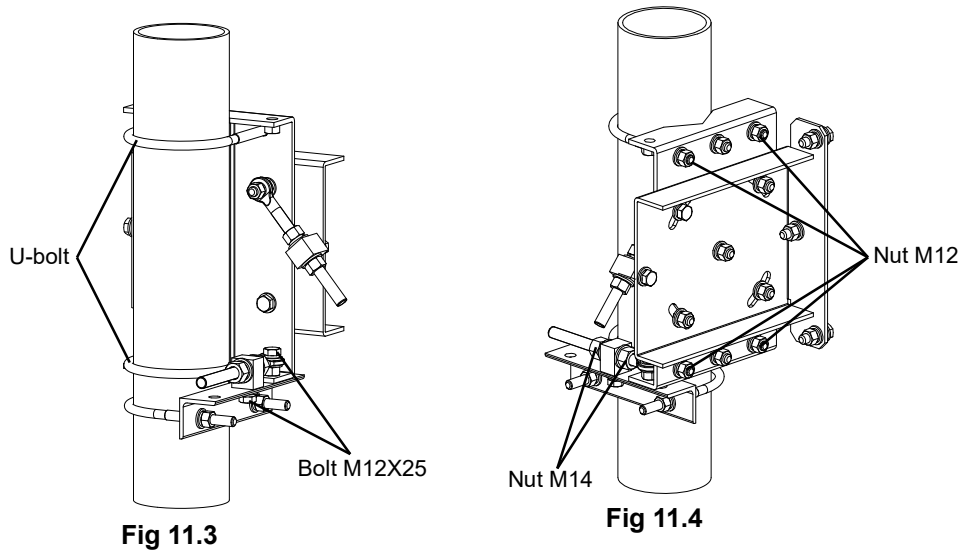

- ① Loosen M12 Nut of U-bolt and M12X25 bolt (shown in Fig 11.3), and then rotate M14 Nut clockwise or counterclockwise to make azimuth adjustment (shown in Fig 11.4).
- ② Antenna can be adjusted from  $-10^{\circ}$  to  $+10^{\circ}$ .
- ③ Tighten all the standard parts.

## 11.3 Polarization Adjustment

This model of microwave antenna provides either vertical or horizontal polarization options. By default the vertical polarization is adopted, as shown in Fig 11.5, Should a customer need alternative configuration, it could be switched and adjusted according to Fig 11.5 ~ Fig 11.6.

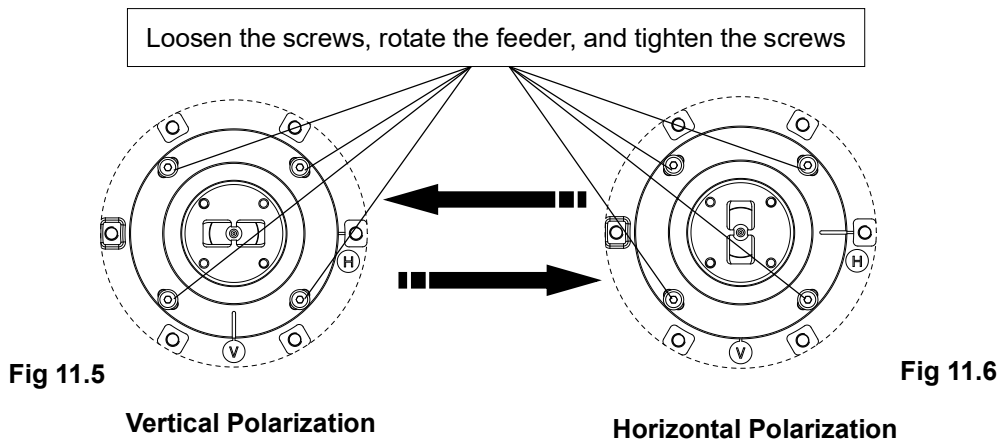

## 12. Antenna Assembly Finishing

- 12.1 Tighten all the standard parts after antenna assembly and installation is completed. Ensure that the correct torque is used for all fasteners per section 1.3.
- 12.2 Remove the plugs from the antenna bottom drain holes but leave the top two sealed. (Shown in Fig 12.1).
- 12.3 Attach the O-ring provided to the Antenna Transition and apply the provided silicone grease around the O-ring before attaching the ODU.

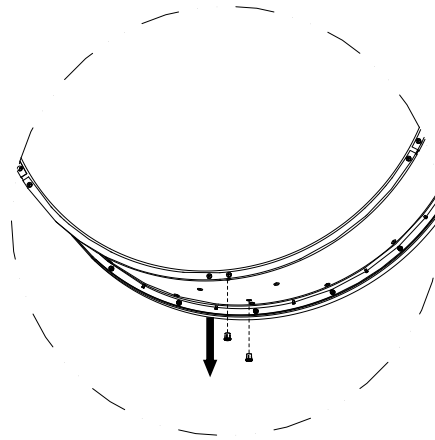

Fig 12.1